



Visibility Sensor PWD50



Features

- Accurate, traceable measurement of prevailing visibility
- Upgradable
- Versatile and easy to install
- Easy to integrate
- Robust and dependable
- Weather-proof design reduces need for maintenance

Dependable operation of automated observation networks is a must today. Maritime observing systems need to work in inhospitable environments and also meteorological institutes face tough productivity and performance prerequisites. Vaisala Visibility Sensor PWD50 answers these needs with a mixture of robustness, dependability, versatility, and reliability. PWD50 measures visibility from 10 m to 35 km (from 32 ft to 21 mi).

Accurate Visibility Measurement

Calibrated with reference to a highly accurate transmissometer, PWD50 uses the proven forward-scatter measurement principle to measure meteorological optical range (MOR). The sensor optics are well-protected against contamination: the optical components point downwards, and hoods protect the lenses against precipitation, spray, and dust. This weather-proof design helps to sustain accurate measurement results.

Versatility

PWD50 architecture allows for easy integration to existing or newly designed systems in a cost-efficient manner. The sensor can be mounted on existing masts in many ways. The electrical interfaces are in a single cable. Versatility is further enhanced with various options,

such as pole masts, a selection of mounting adapters, power supply cabinets, and a modem for long distance communication.

PWD50 can also be upgraded with present weather sensing capabilities to PWD52. The upgrade enables a wide range of valuable outputs, including present weather, precipitation type, precipitation rate and accumulation. These complement the versatile use of the sensor.

Robust and Dependable

The downward-facing sensor hoods protect the optical surfaces from contamination, resulting in low maintenance needs and costs. The optional hood heaters prevent the build-up of ice and/or snow in the optical path.

Solid Track Record

Thousands of PWD series sensors have been installed all around the world. They have undergone rigorous test programs. In the field, the sensors have demonstrated very low failure rates. They have proved their robustness in the harshest climates and most demanding conditions, ranging from offshore to desert and from airport to roadside.



PWD50 reports meteorological visibility reliably from 10 meters to 35 kilometers (from 32 feet to 21 miles).

Technical Data

Visibility Measurement Performance

Operating principle	Forward scatter measurement
Observation range of MOR (Meteorological Optical Range)	10 ... 35 000 m (32 ... 114 800 ft)
Accuracy	±10 % at 10 ... 10 000 m (32 ... 32 800 ft) ±20 % at 10 ... 35 km (6.2 ... 22 mi)

Inputs and Outputs

Power supply	12 ... 50 VDC (electronics) 24 VAC or 24 VDC for heater option
Maximum power consumption	3 W With optional luminance sensor: 2 W, 24 V With optional hood heaters: 65 W, 24 V
Outputs	Serial data line may be used either as RS-232 or RS-485 (2-wire) level signals 3 relay controls (open collector) Analog output current: 0 ... 1 mA or 4 ... 20 mA 8-m power/data cable standard. The PWD end is equipped with connector.
Auxiliary data	Low visibility alarms in the data messages. 3 adjustable alarm limits to set the 3 relay controls. Hardware status (fail/warning) in the data messages. Third relay control output can also be driven by hardware status.

Operating Environment

Operating temperature	-40 ... +60 °C (-40 ... +140 °F)
Operating humidity	0 ... 100 %RH
IP rating	IP66

Mechanical Specifications

Weight	3 kg (6.61 lb)
Dimensions (H × W × D)	199 × 695 × 404 mm (7.83 × 27.36 × 15.91 in)

Compliance

EMC Compliance

Radiated emissions	CISPR 16-1 CISPR 16-2
Radiated susceptibility	IEC 61000-4-3, 10 V/m
Conducted emissions	CISPR 16-1 CISPR 16-2
Conducted susceptibility	IEC 61000-4-6
EFT immunity	IEC 61000-4-4
ESD immunity	IEC 61000-4-2
Surge	IEC 61000-4-5

Spare Parts and Accessories

Pole mast
Interface unit with power supplies: 115/230 VAC
Luminance sensor PWL111
Hood heaters for harsh winter conditions
Support arm for mast installations
Pole clamp kit for mast top installations
Calibration set PWA12
Maintenance cable 16385ZZ

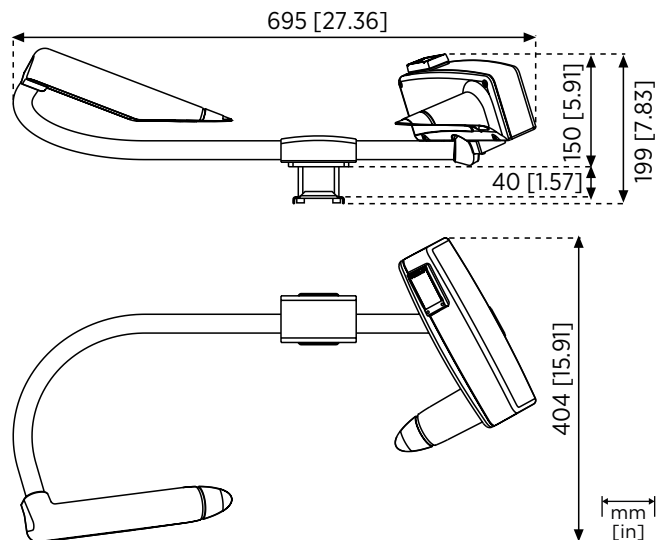

In addition to meteorological observation networks, PWD50 is also well-suited for use in offshore operations.



VAISALA

www.vaisala.com

Published by Vaisala | B211069EN-B © Vaisala 2017

All rights reserved. Any logos and/or product names are trademarks of Vaisala or its individual partners. Any reproduction, transfer, distribution or storage of information contained in this document is strictly prohibited. All specifications — technical included — are subject to change without notice.